



BMA 0007

Instruction and Installation Manual **SPIDEX[®]**

- Torsional elasticity
- Dampening
- Blind assembly
- Safe against break-down
- No maintenance
- Hub material: Aluminium (Al), Cast Iron (GG/GGG), Sintered Steel (Si), Steel (St)

Table of Contents

1.0 General Information:	4
1.1 Safety & Caution Notices:	4
1.2 General Hazard Information:	5
2.0 Intended Use	5
2.1 Note on the EC Machinery Directive 2006/42/EC	5
3.0 Storage, Transport and Packaging	6
3.1 Storage	6
3.2 Transport and Packaging	6
4.0 Dimensions and Sizing	7
4.1 SPIDEX® jaw coupling – Standard version	7
4.2 SPIDEX® jaw coupling – Flange design	8
4.3 SPIDEX® Sizing selection process	9
5.0 Assembly	12
5.1 Assembly Instructions	12
5.2 Coupling components	13
5.3 Assembly of the SPIDEX® coupling	14
5.4 Types of shaft misalignments and values	15
5.5 Information on the finished bore	16
6.0 First Use	18
7.0 Spare Parts Management & Disposal	19
8.0 Maintenance and Inspection	19
8.1 Information on wear values	20
9.0 Errors and faults	21
10.0 Important information for explosion hazard areas	23
10.1 Permissible coupling versions for the EX area	23
10.2 Permissible coupling materials in explosion hazard areas	23
10.3 Explosion hazard area operating conditions	24
10.3.1 Device groups	24

10.3.2 Temperature classes, ambient temperature and surface temperature24

10.4 Health and Safety Information 25

10.5 Installation and assembly 26

10.6 Checks, inspection and repair 27

10.7 Checking 27

11.0 Additional Information:27

Declaration of conformity 28

Table list

Table 1 : Dimensions SPIDEX® jaw coupling..... 7

Table 2 : Dimensions SPIDEX® flange coupling series F..... 8

Table 3 : Dimensions SPIDEX® flange coupling series FF..... 8

Table 4 : Operating factors K1 – Application:..... 10

Table 5 : Operating factors K2 – for starts per hour..... 10

Table 6 : Operating factors K3 – for ambient temperatures 10

Table 7:Performance data table of ring gears..... 11

Table 8 : Tightening torques for set screws..... 14

Table 9 : Tightening torques for clamping screws..... 14

Table 10 : Shaft misalignment values..... 15

Table 11 Max. wear values on the spider 20

List of figures

Figure 1 : Drawing SPIDEX® jaw coupling 7

Figure 2 : Drawing SPIDEX® flange coupling series F / FF series..... 8

Figure 3 : SPIDEX® jaw coupling – assembly 13

Figure 4 : SPIDEX® jaw coupling with clamping version – assembly..... 13

Figure 5 : Shaft misalignment types and values..... 15

Figure 6 : Distance and size of set screw 16

Figure 7 : Method with feeler gage 20

Figure 8 : Wear on the spider 20

Protection Note	Drawn: 02/05/2020 Eata	Replacement for: 10/05/2010 Mboz
Observe ISO 16016	Reviewed: 04/15/2020 Mboz	Replaced by: 02/05/2019 Eata

The flexible **SPIDEX®** coupling transmits the torque positively and reliably. Elastic couplings reduce short-term torque shocks by temporarily elastic storage of some of the shock energy. The ball-shaped involute tooth allows the balancing of radial and angular displacements of the shafts to be connected.

1.0 General Information:

In order to ensure smooth operation of the jaw coupling, the coupling must be dimensioned according to the design regulations DIN 740 Part 2, depending on the application. See page 9 for instructions on the selection process. In the event that the operating conditions of the application change, a new coupling design is mandatory.

Read these assembly instructions carefully before installing the SPIDEX® jaw coupling. Pay special attention to the safety instructions!

The assembly instructions are part of your product. Keep them carefully and close to the SPIDEX® jaw coupling.



SPIDEX® jaw couplings with identification according to 10.3.1 are suitable for use in explosive atmospheres. Please observe the information in the chapter “Important information in explosion hazard areas”.

The copyright of these assembly instructions remains with **R+L Hydraulics GmbH**.

1.1 Safety & Caution Notices:



Danger

Risk of personal injury



Caution

Damage to the machine may occur



Note

Alert to important information



ATEX

Notes/regulations for use in explosion hazard areas



**Hot
surfaces**

Indication of hot surfaces

1.2 General Hazard Information:



During assembly and disassembly of the SPIDEX® jaw coupling ensure that the entire driveline is isolated and protected against accidental switch-on and the system is depressurized. Improper handling of rotating parts can cause serious injury.

It is therefore essential to read and follow the following safety instructions.

- All work with the SPIDEX® jaw coupling must be carried out under the aspect of “safety first”.
- Isolate the drive unit before using the SPIDEX® jaw coupling Carrying out work.
- Isolate the drive unit against unintentional switching on, e.g. by posting alert signs to the switch-on point or remove the fuse on the power supply.
- Do not reach into the working range of the coupling when it is still in operation.
- Secure rotating drive parts from accidental contact. Attach appropriate protective devices and covers.

2.0 Intended Use

You may only install, operate and service the SPIDEX® jaw coupling if you:

- have read and understood the assembly instructions carefully
- are authorized and professionally trained

The SPIDEX® jaw coupling may only be used in accordance with the technical specifications. Unauthorized structural modifications of the SPIDEX® jaw coupling are not permitted. We do not assume any liability for resulting damage. In the interest of further development, we reserve the right to make technical revisions. The SPIDEX® jaw coupling described here corresponds to the state of the art at the time of printing of this assembly instruction. The SPIDEX® jaw coupling is generally supplied ready for assembly.

2.1 Note on the EC Machinery Directive 2006/42/EC

Couplings supplied by R+L Hydraulics are considered as components and are not to be classified as machines or incomplete machines within the meaning of EC Machinery Directive 2006/45/EC. Consequently, R+L Hydraulics does not have to issue a declaration of incorporation. For safe installation and operation, please observe the warning notices in these operating/assembly instructions.

Protection Note	Drawn: 02/05/2020 Eata	Replacement for: 10/05/2010 Mboz
Observe ISO 16016	Reviewed: 04/15/2020 Mboz	Replaced by: 02/05/2019 Eata

3.0 Storage, Transport and Packaging

3.1 Storage

The following chapter covers storage instructions for the SPIDEX® jaw coupling:

- coupling hubs can be stored in a covered, dry place for 6-9 months.
- the characteristics of the coupling ring gears remain unchanged for up to 5 years under favorable storage conditions.



Storage rooms must not contain ozone-producing devices, such as fluorescent light sources, mercury vapor lamps or electrical high-voltage devices. Damp storage rooms are unsuitable. Care must be taken to ensure that no condensation occurs. The favorable relative humidity is below 65%.

3.2 Transport and Packaging



To avoid injuries and various types of damage, always use suitable means of transport and lifting equipment.

Couplings are packaged differently depending on the dimensions/size, quantity and type of transport. If no packing instructions have been agreed upon at the time of placing the order, the packaging shall be in accordance with the internal packaging regulation of R+L Hydraulics GmbH

Protection Note	Drawn: 02/05/2020 Eata	Replacement for: 10/05/2010 Mboz
Observe ISO 16016	Reviewed: 04/15/2020 Mboz	Replaced by: 02/05/2019 Eata

4.0 Dimensions and Sizing

4.1 SPIDEX® jaw coupling – Standard version

Figure 1 : Drawing SPIDEX® jaw coupling

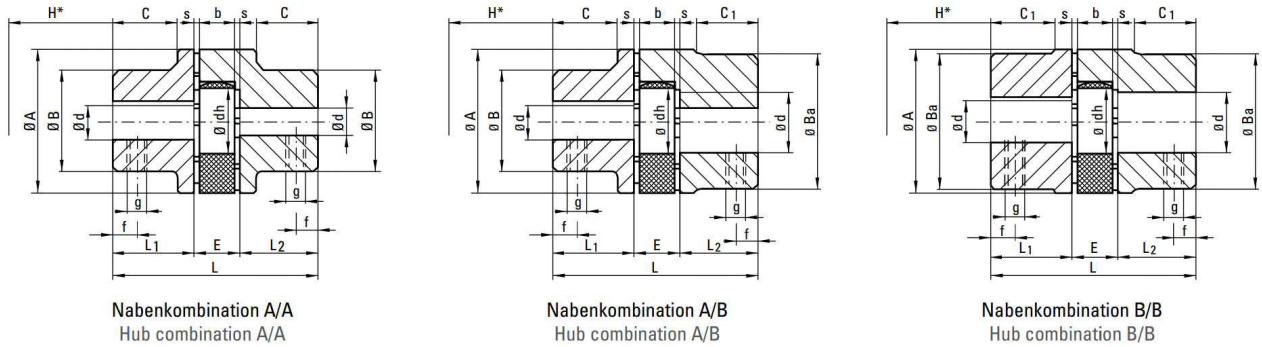

Table 1 : Dimensions SPIDEX® jaw coupling

SPIDEX®	Fertigbohrung Finish bore [mm]				Abmessungen Dimensions [mm]														Gewicht Weight [kg]	Naben Sonderlänge Special hub length [mm]	
	Nabe A Hub A		Nabe B Hub B		A	B	Ba	L	L1/L2	E	s	b	C	C1	dh	g	f	H*			
	min	max	min	max																	
Werkstoff: Aluminium Druckguss (ALU), Aluminium (Al) Material: die-cast aluminium (ALU), Aluminium (Al)																					
A15	–	–	4	15	26	–	26	28	10	8	1.0	6	–	–	12	M5	5	8	0.025	–	
A19/24	6	19	19	24	40	32	39	66	25	16	2.0	12	20	21	18	M5	10	14	0.130	55	
A24/32	8	24	16	32	55	40	53	78	30	18		14	24	26	27	M5		16	0.260	60	
A28/38	10	28	28	38	65	48	63	90	35	20	2.5	15	28	29	30	M6	15	18	0.460	60	
A38/45	14	38	38	45	80	66	79	114	45	24	3.0	18	37	39	38	M8		19	0.900	70	
Werkstoff: Grauguss (GG), Sphäroguss (GGG), Stahl (St), Sinterstahl (Si) Material: cast iron (GG), SG iron (GGG), steel (St), sintered steel (Si)																					
A14/16 St	–	–	4	16	30	–	30	35	11	13	1.5	10	–	–	10	M4	5	12	0.140	18.5	
A19/24 GG/St/Si	6	19	12	24	40	32	39	66	25	16	2.0	12	20	21	18	M5	10	14	0.350	55	
A24/32 GG/St/Si	10	24	14	32	55	40	52	78	30	18		14	24	26	27			16	1.000	60	
A28/38 GG/St/Si	12	28	28	38	65	48	62	90	35	20	2.5	15	28	29	30	M6	15	18	1.600	80	
A38/45 GG/GGG/St/Si	14	38	38	45	80	66	77	114	45	24	3.0	18	37	37	38			19	2.300	110	
A42/55 GG/GGG/St/Si	19	42	42	55	95	75	94	126	50	26	3.0	20	40	40	46	M8	20	21	3.600	110	
A48/60 GG/GGG/St/Si	19	48	48	60	105	85	102	140	56	28	3.5	21	45	45	51			22	4.800	110	
A55/70 GG/GGG/St	19	55	55	70	120	98	118	160	65	30	4.0	22	52	52	60	M10	25	23	7.400	140	
A65/75 GG/GGG/St	22	65	65	75	135	115	132	185	75	35	4.5	26	61	59	68			27	10.900	140	
A75/90 GG/GGG/St	30	75	75	90	160	135	158	210	85	40	5.0	30	69	65	80		31	17.700	195		
A90/100 GG/GGG/St	40	90	90	100	200	160	180	245	100	45	5.5	34	81	81	100		35	29.500	140/210		
A100/110 GG/GGG/St	–	–	55	110	225	–	200	270	110	50	6.0	38	–	89	113		30	39	43.500	–	
A110/125 GG/GGG/St	–	–	65	125	255	–	230	295	120	55	6.5	42	–	96	127	M16	40	35	63.000	–	
A125/145 GG/GGG/St	–	–	65	145	290	–	265	340	140	60	7.0	46	–	112	147			40	47	95.000	–

Protection Note	Drawn: 02/05/2020 Eata	Replacement for: 10/05/2010 Mboz
Observe ISO 16016	Reviewed: 04/15/2020 Mboz	Replaced by: 02/05/2019 Eata

4.2 SPIDEX® jaw coupling – Flange design

Figure 2 : Drawing SPIDEX® flange coupling series F / FF series

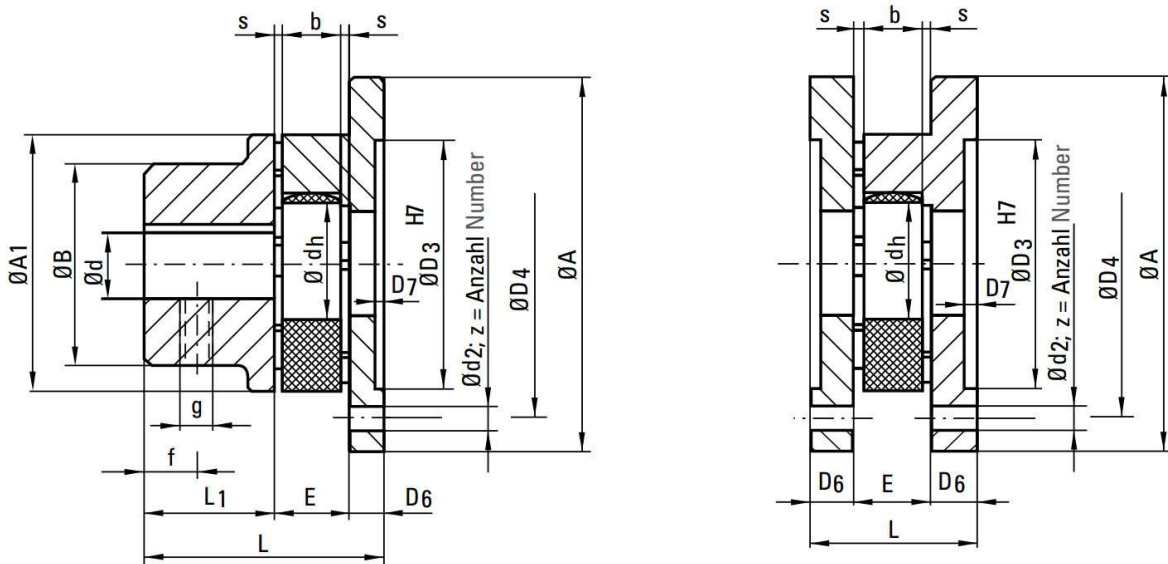

Table 2 : Dimensions SPIDEX® flange coupling series F.

BAUREIHE F

SPIDEX®	Fertigbohrung ¹⁾ Finish bore ¹⁾ [mm]		Abmessungen Dimensions [mm]																	Gewicht Weight [kg]	Massen- trägheits- moment ²⁾ Moment of inertia ²⁾ J [kg m ²]
	min	max ⁴⁾	A	A1	B	L1	L	E	s	b	dh	g	f	D6	D7	d2 DIN 69	z Anzahl Number	D3	D4		
F 28	10	28	100	65	65	35	65	20	2.5	15	30	M8	15	10	1.5	7	6	65	80	1.18	0.0012
F 38	14	38	115	80	66	45	79	24	3.0	18	38	M8	15	10	1.5	7	6	80	95	1.87	0.0023
F 42	19	42	140	95	75	50	88	26	3.0	20	46	M8	20	12	2.0	9	6	95	115	3.06	0.0054
F 48	19	48	150	105	85	56	96	28	3.5	21	51	M8	20	12	2.0	9	8	105	125	3.88	0.0080
F 55	19	55	175	120	98	65	111	30	4.0	22	60	M10	20	16	2.0	11	8	120	145	6.21	0.0178
F 65	22	65	190	135	115	75	126	35	4.5	26	68	M10	20	16	2.0	11	10	135	160	8.63	0.0293
F 75	30	75	215	160	135	85	144	40	5.0	30	80	M10	25	19	2.5	14	10	160	185	13.20	0.0595
F 90	40	90	260	200	160	100	165	45	5.5	34	100	M12	30	20	3.0	14	12	200	225	22.00	0.1443

Table 3 : Dimensions SPIDEX® flange coupling series FF

BAUREIHE FF

SPIDEX®	Abmessungen Dimensions [mm]													Gewicht Weight [kg]	Massen- trägheits- moment ²⁾ Moment of inertia ²⁾ J [kg m ²]
	A	L	E	s	b	dh	D6	D7	d2 DIN 69 ³⁾	z Anzahl Number	D3	D4			
FF 28	100	40	20	2.5	15	30	10	1.5	7	6	65	80	1.19	0.0015	
FF 38	115	44	24	3.0	18	38	10	1.5	7	6	80	95	1.66	0.0028	
FF 42	140	50	26	3.0	20	46	12	2.0	9	6	95	115	2.91	0.0072	
FF 48	150	52	28	3.5	21	51	12	2.0	9	8	105	125	3.35	0.0092	
FF 55	175	62	30	4.0	22	60	16	2.0	11	8	120	145	5.78	0.0230	
FF 65	190	67	35	4.5	26	68	16	2.0	11	10	135	160	7.13	0.0340	
FF 75	215	78	40	5.0	30	80	19	2.5	14	10	160	185	10.50	0.0650	
FF 90	260	85	45	5.5	34	100	20	3.0	14	12	200	225	16.50	0.1500	

4.3 SPIDEX® Sizing selection process

<p><u>Step 1:</u> Determination of the nominal torque of your application:</p> $T_N \text{ [Nm]} = \frac{P \text{ [kW]} \times 9550}{n \text{ [rpm]}}$	<p><u>Step 2:</u> Calculation of the operating factor of your application using the factors from Table 4-6. The total operating factor “K” is derived from:</p> $K = K1 \times K2 \times K3$
<p><u>Step 3:</u> Calculation of the structural torque “T_{NK}” of your application:</p> $T_{NK} = T_N \times K.$	<p><u>Step 4:</u> Using the Elastomer Performance Data Table (Table 7), select the urethane shore hardness level that best meets the relative damping requirements of your application</p>
<p><u>Step 5:</u> Next, find the columns in which the values T_{KN} and T_{Kmax} are listed in Nm and compare them with the value T_{NK} for your application. Ensure that the values of the spider are greater than the application values.</p> $T_{KN} \ \& \ T_{Kmax} > T_{NK}$	<p><u>Step 6:</u> Once the size is selected using the torque values, use the tables on pages 8-9 to ensure that the required bore diameter fits into the coupling.</p>
<p><u>Step 7:</u> Carefully check the total dimension of the coupling to ensure that the coupling fits into the installation space.</p>	<p>This selection process is a simplified method for sizing our SPIDEX® coupling. For a more precise selection, DIN 704 T2 should be used. The shaft-hub connection must be checked by the customer!</p>
T _N [Nm]	Nominal torque of the application
T _{Kmax} [Nm]	Maximum torque of the coupling
P [kW]	Power in kilowatts
n [rpm]	Revolution per minute
Nm	Newton-meter
T _{NK} [Nm]	Design torque of the application
T _{KW} [Nm]	Alternating torque
K	Operating factor

Table 4 : Operating factors K1 – Application:

	Operating factor K1
Smooth operation with small acceleration masses. Hydraulic and centrifugal pumps, small generators, fans, blowers, belt/screw conveyors	1.0
Smooth operation with medium acceleration masses. Sheet metal bending machines, woodworking machines, rolling mills, textile machines, mixers	1.2
Uneven operation with medium acceleration masses. Rotating furnaces, printing presses, generators, shredders, winding machines, spinning machines, pumps for thick fluids.	1.3
Uneven operation and shock loads with medium acceleration masses. Concrete mixers, drop hammers, cable cars, paper mills, compression pumps, propeller pumps, cable winches, centrifuges.	1.6
Uneven operation and very strong shock loads with very large acceleration masses. Piston compressors and pumps without speed control, heavy roller sets, welding machines, brick presses, stone crushers.	1.8

Table 5 : Operating factors K2 – for starts per hour

Starts per hour	100	200	400	800
K2	1.0	1.2	1.4	1.6

Table 6 : Operating factors K3 – for ambient temperatures

Spider type	-50 °C	-30 °C to +30°	+40 °C	+50 °C	+60 °C	+70 °C	+80 °C	+90 °C	+100 °C	+110 °C	+120 °C
Standard	-	1.0	1.2	1.3	1.4	1.55	1.8	2.2	-	-	-
High Temperature	1.0	1.0	1.1	1.2	1.3	1.45	1.6	1.8	2.1	2.5	3.0

Table 7: Performance data table of ring gears

Zahnkranz Spider	Größe Size	Drehmoment Torque [Nm]			Max. Drehzahl Max. RPM n [1/min]		Verdrehwinkel Torsional angle		Drehfedersteife Torsional stiffness C _{dyn} [Nm/rad]				Verhältnismäßige Dämpfung Relative damping	
		Nenn Contin T _{KN}	Maximal Maximum T _{Kmax}	Wechsel Alternat. T _{KW}	v*		T _{KN} Φ _{KN}	T _{Kmax} Φ _{Kmax}	1.00 T _{KN}	0.75 T _{KN}	0.5 T _{KN}	0.25 T _{KN}		
					30 m/s	40 m/s								
92° Shore A Farbe: Weiß Colour: White	14/16, 15	7.5	15	2.0	19000	–	6.4°	10°	0.38 x 10 ³	0.31 x 10 ³	0.24 x 10 ³	0.14 x 10 ³	0.75	
	19/24	10.0	20	2.6	14000	19000	3.2°	5°	1.28 x 10 ³	1.05 x 10 ³	0.80 x 10 ³	0.47 x 10 ³		
	24/32	35.0	70	9.1	10600	14000			4.86 x 10 ³	3.98 x 10 ³	3.01 x 10 ³	1.79 x 10 ³		
	28/38	95.0	190	25.0	8500	11800			10.90 x 10 ³	8.94 x 10 ³	6.76 x 10 ³	4.01 x 10 ³		
	38/45	190.0	380	49.0	7100	9500			21.05 x 10 ³	17.26 x 10 ³	13.05 x 10 ³	7.74 x 10 ³		
	42/55	265.0	530	69.0	6000	8000			23.74 x 10 ³	19.47 x 10 ³	14.72 x 10 ³	8.73 x 10 ³		
	48/60	310.0	620	81.0	5600	7100			36.70 x 10 ³	30.09 x 10 ³	22.75 x 10 ³	13.49 x 10 ³		
	55/70	410.0	820	107.0	4750	6300			50.72 x 10 ³	41.59 x 10 ³	31.45 x 10 ³	18.64 x 10 ³		
	65/75	625.0	1250	163.0	4250	5600			97.13 x 10 ³	79.65 x 10 ³	60.22 x 10 ³	35.70 x 10 ³		
	75/90	1280.0	2560	333.0	3550	4750			113.32 x 10 ³	92.92 x 10 ³	70.26 x 10 ³	41.65 x 10 ³		
	90/100	2400.0	4800	624.0	2800	3750			190.09 x 10 ³	155.87 x 10 ³	117.86 x 10 ³	69.86 x 10 ³		
	100/110	3300.0	6600	858.0	2500	3350			253.08 x 10 ³	207.53 x 10 ³	156.91 x 10 ³	93.01 x 10 ³		
	110/125	4800.0	9600	1248.0	2240	3000			311.61 x 10 ³	255.52 x 10 ³	193.20 x 10 ³	114.52 x 10 ³		
	125/145	6650.0	13300	1729.0	2000	2650			474.86 x 10 ³	389.39 x 10 ³	294.41 x 10 ³	174.51 x 10 ³		
98° Shore A Farbe: Rot Colour: Red	14/16, 15	12.5	25	3.3	19000	–			3.2°	5°	0.56 x 10 ³	0.46 x 10 ³	0.35 x 10 ³	0.21 x 10 ³
	19/24	17.0	34	4.4	14000	19000	6.4°	10°	2.92 x 10 ³	2.39 x 10 ³	1.81 x 10 ³	1.07 x 10 ³		
	24/32	60.0	120	16.0	10600	14000	3.2°	5°	9.93 x 10 ³	8.14 x 10 ³	6.16 x 10 ³	3.65 x 10 ³		
	28/38	160.0	320	42.0	8500	11800			26.77 x 10 ³	21.95 x 10 ³	16.60 x 10 ³	9.84 x 10 ³		
	38/45	325.0	650	85.0	7100	9500			48.57 x 10 ³	39.83 x 10 ³	30.11 x 10 ³	17.85 x 10 ³		
	42/55	450.0	900	117.0	6000	8000			54.50 x 10 ³	44.69 x 10 ³	33.79 x 10 ³	20.03 x 10 ³		
	48/60	525.0	1050	137.0	5600	7100			65.29 x 10 ³	53.54 x 10 ³	40.48 x 10 ³	24.00 x 10 ³		
	55/70	685.0	1370	178.0	4750	6300			94.97 x 10 ³	77.88 x 10 ³	58.88 x 10 ³	34.90 x 10 ³		
65/75	940.0	1880	244.0	4250	5600	129.51 x 10 ³			106.20 x 10 ³	80.30 x 10 ³	47.60 x 10 ³			
75/90	1920.0	3840	499.0	3550	4750	197.50 x 10 ³			161.95 x 10 ³	122.45 x 10 ³	72.58 x 10 ³			
95° Shore A Farbe: Rot Colour: Red	90/100	3600.0	7200	936.0	2800	3750	3.2°	5°	312.20 x 10 ³	256.00 x 10 ³	193.56 x 10 ³	114.73 x 10 ³		
	100/110	4950.0	9900	1287.0	2500	3350			383.26 x 10 ³	314.27 x 10 ³	237.62 x 10 ³	140.85 x 10 ³		
	100/125	7200.0	14400	1872.0	2240	3000			690.06 x 10 ³	565.85 x 10 ³	427.84 x 10 ³	253.60 x 10 ³		
95° Shore A Farbe: Natur Colour: Nature	125/145	10000.0	20000	2600.0	2000	2650	3.2°	5°	1343.64 x 10 ³	1101.79 x 10 ³	833.06 x 10 ³	493.79 x 10 ³		
	24/32	75.0	150	19.5	10600	14000			2.5°	3.6°	15.11 x 10 ³	12.39 x 10 ³	9.37 x 10 ³	5.55 x 10 ³
	28/38	200.0	400	52.0	8500	11800					27.52 x 10 ³	22.57 x 10 ³	17.06 x 10 ³	10.12 x 10 ³
38/45	405.0	810	105.0	7100	9500	70.15 x 10 ³	57.52 x 10 ³	43.49 x 10 ³			25.78 x 10 ³			
42/55	560.0	1120	146.0	6000	8000	79.86 x 10 ³	65.49 x 10 ³	49.52 x 10 ³			29.35 x 10 ³			
48/60	655.0	1310	170.0	5600	7100	95.51 x 10 ³	78.32 x 10 ³	59.22 x 10 ³			35.10 x 10 ³			
55/70	825.0	1650	215.0	4750	6300	107.52 x 10 ³	88.50 x 10 ³	66.91 x 10 ³			39.66 x 10 ³			
65/75	1175.0	2350	306.0	4250	5600	151.09 x 10 ³	123.90 x 10 ³	93.68 x 10 ³			55.53 x 10 ³			
75/90	2400.0	4800	624.0	3550	4750	248.22 x 10 ³	203.54 x 10 ³	153.90 x 10 ³			91.22 x 10 ³			
90/100	4500.0	9000	1170.0	2800	3750	674.52 x 10 ³	553.11 x 10 ³	418.20 x 10 ³			247.89 x 10 ³			

5.0 Assembly

The SPIDEX® jaw coupling is generally supplied ready for assembly.

5.1 Assembly Instructions



We recommend checking the dimensional accuracy of the bore, shaft, groove and key before assembly.



By slightly heating the hubs to approx. 80 °C, it is possible to apply them to the shaft more easily.



Touching the heated coupling hubs may cause burns. Always wear safety gloves during assembly.



During assembly, ensure that the E dimension, see Table 1-3, is maintained for the spider to remain axially movable in use. In the event of disregard, the coupling cannot operate correctly and possibly incur damage.



Pay attention to the risk of ignition in explosion hazard areas.

Protection Note	Drawn: 02/05/2020 Eata	Replacement for: 10/05/2010 Mboz
Observe ISO 16016	Reviewed: 04/15/2020 Mboz	Replaced by: 02/05/2019 Eata

5.2 Coupling components

Figure 3 : SPIDEX® jaw coupling – assembly

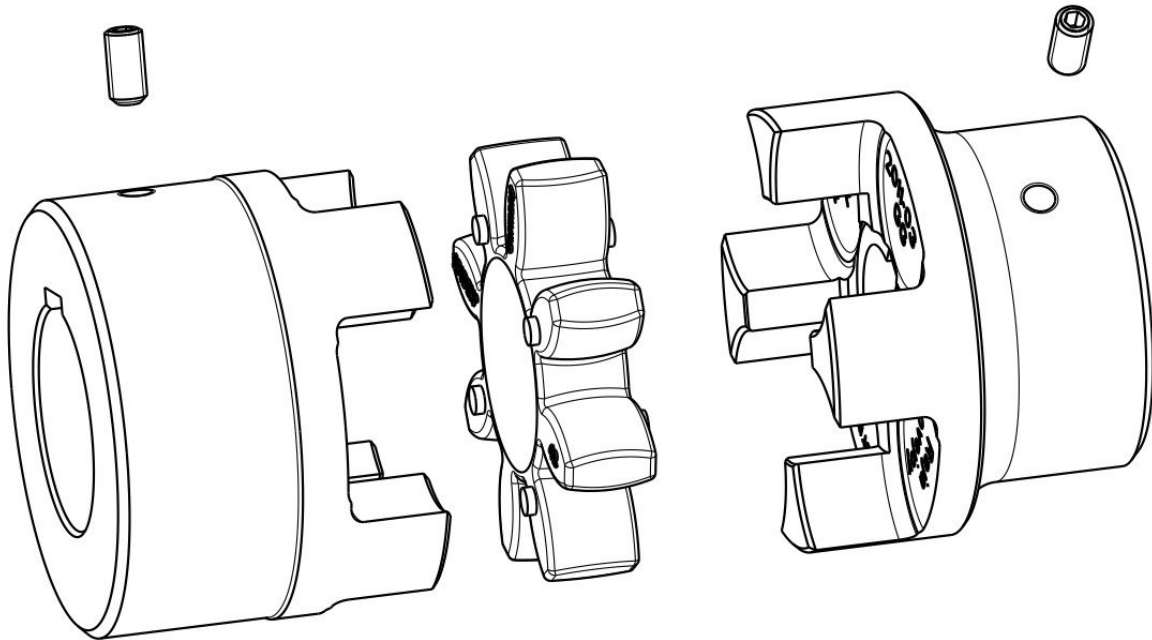
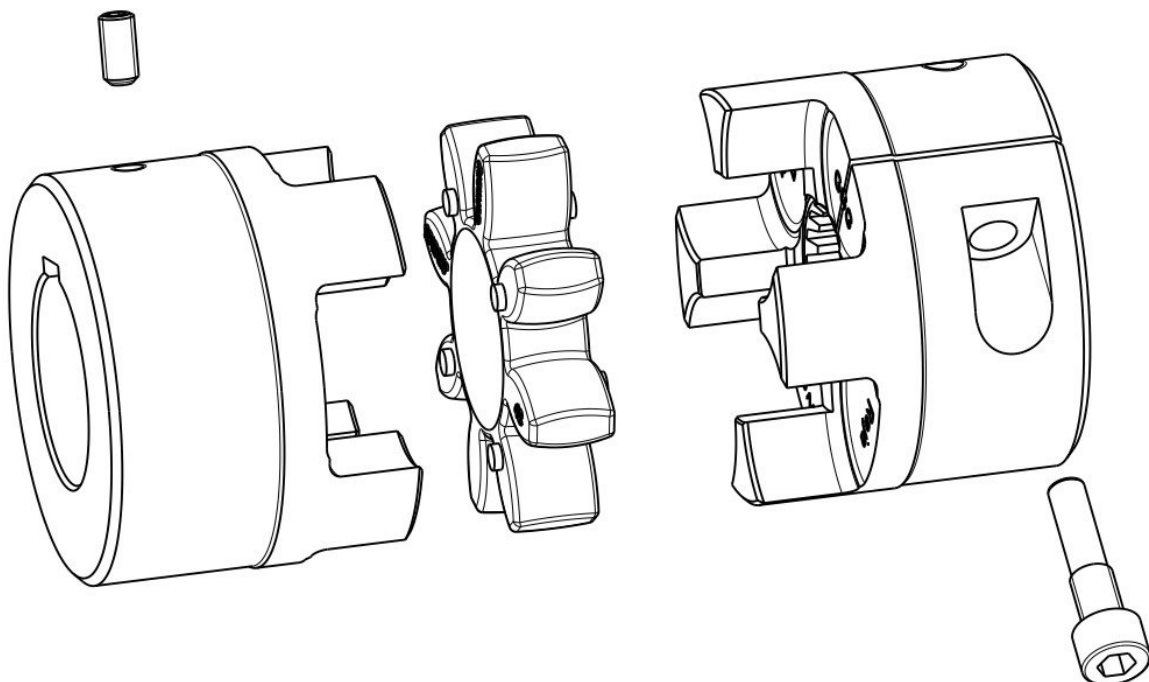

Figure 4 : SPIDEX® jaw coupling with clamping version – assembly



5.3 Assembly of the SPIDEX® coupling

- Clean the finish bore/spline before starting coupling assembly. The finish bore/spline must not contain preservatives after cleaning. Furthermore, the shaft ends must be cleaned and degreased.



Observe the manufacturer's instructions for use of cleaning agents.

- Install the two coupling hubs onto the shaft of the drive side and the output side.
- Insert the spider into the cam geometry on either side.
- If you have an assembly drawing, fix the two coupling hubs as indicated on the drawing. The E dimension, Table 1-3, must be checked and adjusted if necessary.
- If you do not have an assembly drawing, join the unit together axially until the E dimension, Table 1-3, is reached.
- If the units are already fixed on the motor and pump side, adjust the E dimension, Table 1-3, by axially moving the coupling hubs.
- Secure the hubs by tightening the radial set screws DIN EN ISO 4029 with annular cutting edge. Refer to Table 8 for the tightening torques.
- If you are installing a SPIDEX® coupling hub in clamping version, refer to Table 9 for the tightening torque.



If the supplied coupling is used in explosion hazard areas, the set screws for hub mounting as well as all screw connections must be secured against “self-loosening”, e.g. bonding with Loctite (medium-strength).

Table 8 : Tightening torques for set screw

Set screw DIN EN ISO 4029 with annular cutting edge	M4	M5	M6	M8	M10	M12	16
Tightening torque T_A [Nm]	1.5	2	4	10	17	40	80

Table 9 : Tightening torques for clamping screws

Socket head screw with hexagon DIN912 – 12.9	M8	M10	16	M20	M24
Tightening torques – T_A [Nm]	25	69	295	410	710

Protection Note	Drawn: 02/05/2020 Eata	Replacement for: 10/05/2010 Mboz
Observe ISO 16016	Reviewed: 04/15/2020 Mboz	Replaced by: 02/05/2019 Eata

5.4 Types of shaft misalignments and values



In order to ensure a long service life of the coupling and to avoid danger when used in explosion hazard areas, the shaft ends must be aligned precisely. It is essential to comply with the specified shaft misalignment values, see Table 10. If the values are exceeded, the coupling will be damaged. The more precisely the coupling is aligned, the greater its service life.

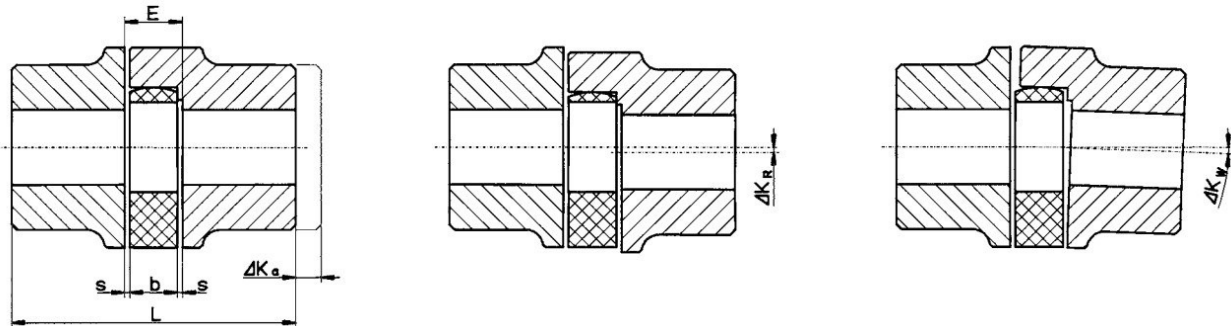

Figure 5 : Shaft misalignment types and values

Table 10 : Shaft misalignment values

SPIDEX®	Abmessungen Dimensions [mm]				Axialversatz Axial displacement ΔK_a [mm]	Radialversatz Radial displacement ΔK_r [mm]				Winkerversatz Angular displacement ΔK_w [°]			
	L	E	b	s		Drehzahl Rotation n [1/min]				Drehzahl Rotation n [1/min]			
						750	1000	1500	3000	750	1000	1500	3000
A14	35	13	10	1.5	1.0	0.22	0.20	0.16	0.11	1.3	1.3	1.2	1.1
A15	28	8	6	1.0		0.27	0.24	0.20	0.13				
A19	66	16	12	2.0	1.2	0.30	0.27	0.22	0.15	1.1	1.0	0.9	0.8
A24	78	18	14	2.0	1.4	0.34	0.30	0.25	0.17				
A28	90	20	15	2.5	1.5	0.38	0.35	0.28	0.19	1.2	1.2	1.1	0.9
A38	114	24	18	3.0	1.8	0.43	0.38	0.32	0.21				
A42	126	26	20	3.0	2.0	0.50	0.44	0.36	0.25	1.3	1.3	1.2	1.0
A48	140	28	21	3.5	2.1	0.54	0.46	0.38	0.26				
A55	160	30	22	4.0	2.2	0.56	0.50	0.42	0.28	1.3	1.3	1.2	1.1
A65	185	35	26	4.5	2.6	0.65	0.58	0.48	0.32				
A75	210	40	30	5.0	3.0	0.68	0.60	0.50	0.34	1.3	1.3	1.2	1.1
A90	245	45	34	5.5	3.4	0.71	0.64	0.52	0.36				
A100	270	50	38	6.0	3.8	0.75	0.67	0.55	0.38	1.3	1.3	1.3	1.1
A110	295	55	42	6.5	4.2	0.80	0.70	0.60	-				
A125	340	60	46	7.0	4.6								

- The shaft misalignment values shown in Table 10 are maximum values that must not occur at the same time. In the case of simultaneous occurrence of radial and angular offset, the permissible shaft misalignment values may only be used proportionally.
- Use a dial gage, ruler or feeler gage to check whether the permissible shaft misalignment values from Table 10 are observed.

Protection Note	Drawn: 02/05/2020 Eata	Replacement for: 10/05/2010 Mboz
Observe ISO 16016	Reviewed: 04/15/2020 Mboz	Replaced by: 02/05/2019 Eata

5.5 Information on the finished bore



The finished bores must not exceed the maximum permissible bore diameter “Ød” (Table 1-3). A larger finished bore than the maximum permitted bore diameter may cause damage to the hub. There is a risk of serious injury or death from the resulting damage.

- If the hub bore is made by the customer, it is essential that the concentric and axial runout accuracy is maintained.
- The maximum bore diameters “Ød” must not be exceeded.
- The hubs must be carefully aligned when making the finished bore.
- A locking screw for the axial locking of the hub according to DIN EN ISO 4029 with annular cutting edge or an end washer must be provided.

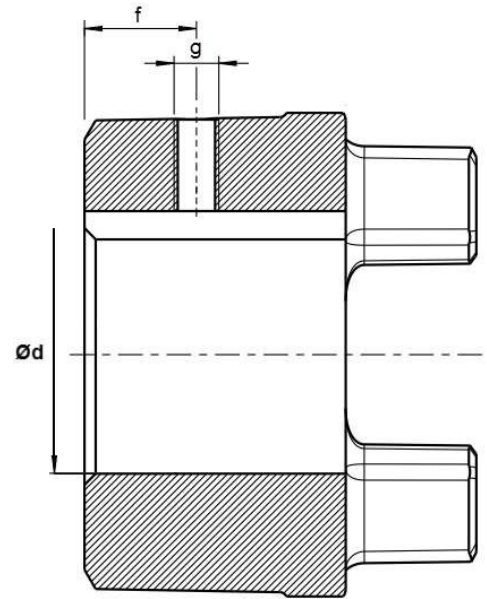

Figure 6 : Distance and size of set screw



The customer bears the sole responsibility for the machining operations carried out in the case of pre-/undrilled hubs. R+L Hydraulics GmbH does not assume any claim for warranty arising from insufficient rework.

Table 7: Thread/locking screws according to DIN EN ISO 4029

Size	14	15	19	24	28	38	42	48	55	65	75	90	100	110	125
Dimension “g”	M4	M5	M5	M5	M6	M8	M8	M8	M10	M10	M10	M10	16	16	16
Dimension “f”	5	5	10	10	15	15	20	20	20	20	25	25	30	35	40
Tightening torque [Nm]	1,5	2	2	2	4	10	10	10	17	17	17	40	40	80	80

In case of hubs with a keyway, the groove tolerance must be produced according to ISO JS9 under “normal” operating conditions. In case of increased operating conditions, such as “frequently changing direction of rotation”, “shock load with large acceleration masses”, etc., the nut tolerance must be produced in accordance with ISO P9. The groove should generally be inserted between the jaws. The threaded hole of the locking screw for the axial locking of the hub is inserted either on the groove or opposite the groove, depending on the bore.

The transmissible nominal torque of the shaft-hub connection must be checked by the customer and is subject to his responsibility.

Table 8: Fit combinations according to DIN 748/1

Bore [mm]		Tolerance of the shaft	Tolerance of the finished bore in the hub
over	to		
-	50	k6	H7
50	-	m6	

6.0 First Use

The following checklist must be carried out before first use:

- The set screw is fixed and mounted with the correct tightening torque
- The “E” dimension is observed
- The correct orientation of the hubs is given
- A coupling guard against accidental contact or falling of objects according to DIN EN ISO 12100 and the directive 2014/34/EU is provided

If a closure or a cover with a gap or several openings is present in the coupling guard, it must be designed in accordance with DIN EN ISO 13857. An aluminum Bellhousing from R+L with a magnesium content below 7.5%, can be used as coupling guard. In addition, the aluminum Bellhousing can also be equipped with a damping ring made of NBR. The cover must be connected to the potential equalization line and must not be electrically conductive. The cover may only be removed when the machine is stopped.



When used in explosion hazard areas, it must be ensured that

- **the screw connections are secured to prevent self-loosening (e.g. with Loctite – medium-strength).**
- **no dust has accumulated between the cover and the coupling. Under no circumstances must the coupling transmit the torque in a “dust cloud”.**
- **for device group II, the covers of the coupling guard without heat vents are made of a non-rusting steel.**
- **if a cover is in place for the coupling in the “Device group I M2”, the cover must not be made of a light metal material and must meet high mechanical requirements.**
- **no electrostatic charge is expected for coated hubs with a film thickness of max. 200 µm. In general, for coated hubs, the conductivity and film thickness requirements must be observed. A coupling with a coating with film thickness of more than 200 µm is not permitted in the explosion hazard area. When using a coated or painted coupling, the electrical conductivity with the adjacent components must be present so that potential equalization is not prevented by the added coating or paint coat. After coating the coupling, it is important to make sure that the designation of the coupling remains readable.**



The system must be isolated immediately if any irregularities in the drive train are noticed. The cause of the error must then be found and eliminated.

Protection Note	Drawn: 02/05/2020 Eata	Replacement for: 10/05/2010 Mboz
Observe ISO 16016	Reviewed: 04/15/2020 Mboz	Replaced by: 02/05/2019 Eata

7.0 Spare Parts Management & Disposal



A spare stock of important spare parts at the place of use is a basic requirement to ensure the coupling is ready for use.



For contact addresses of the field service staff or cooperation partners for spare parts/orders, see the R+L Hydraulics homepage at www.rl-hydraulics.com.

In order to protect the environment, please dispose of the products or the packaging at the end of its useful life in accordance with the applicable legal regulations or guidelines.

- **Metallic products:** Metallic products belong to metal scrap and must be cleaned before.
- **Plastics:** Plastic products must be disposed of properly or by a suitable company.

8.0 Maintenance and Inspection

SPIDEX® is a low-maintenance jaw coupling. The following points must be observed during maintenance:

- The coupling must be visually inspected at least once a year.
- Check the alignment of the coupling and realign if necessary.
- Visually check whether the components are damaged.
- Check the bolt connections.

The spider can wear out due to friction, so that the coupling halves can contact each other and cause a spark of ignition. For this reason, wear should be checked for the first time after 3000 hours and again every 3000 hours or at the latest after 6 months. If the wear is not acceptable, replace the spider.

Protection Note	Drawn: 02/05/2020 Eata	Replacement for: 10/05/2010 Mboz
Observe ISO 16016	Reviewed: 04/15/2020 Mboz	Replaced by: 02/05/2019 Eata

8.1 Information on wear values

During maintenance, it must be ensured that the wear on the spider is within the wear limit, among other things. There are several inspection methods:

- During operation: If the coupling is still in operation, the wear can be checked using electronic devices such as a lightning device (strobe lamp) or a suitable high-speed camera. If other methods are used, they must ensure the same accuracy as a test at standstill
- Standstill: When checking while at standstill, a feeler gage can be used to check the gap between the spider and the jaw on the hub, see Figure 7. The thickness of the feeler gage must be less than the maximum allowable wear values listed in Table 11.



The exact alignment of the shaft ends is necessary to avoid possible dangers when used in explosion hazard areas and promotes the long service life of the coupling used. The shaft misalignment values of the coupling must always be observed, otherwise an increased wear on the components can occur and the coupling may be damaged.

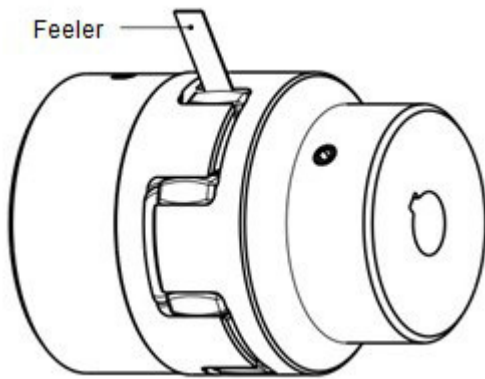

Figure 7 : Method with feeler gage

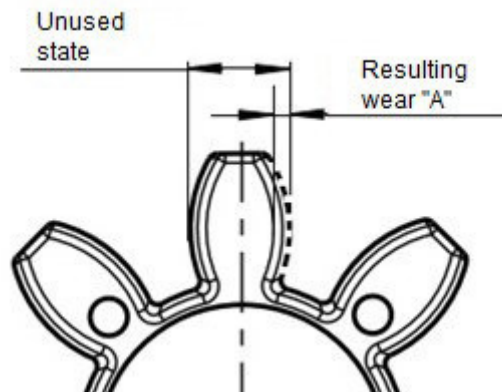

Figure 8 : Wear on the spider

The spider must be replaced if the measured wear is greater than the value “A” in Table 11.

	Coupling size														
	14	15	19	24	28	38	42	48	55	65	75	90	100	110	125
Max. wear “A” [mm]	2	2	3	3	3	3	4	4	5	5	6	8	9	9	10

Table 11 Max. wear values on the spider

Protection Note	Drawn: 02/05/2020 Eata	Replacement for: 10/05/2010 Mboz
Observe ISO 16016	Reviewed: 04/15/2020 Mboz	Replaced by: 02/05/2019 Eata

9.0 Errors and faults

If a SPIDEX® coupling is not used for its intended purpose, the following errors or faults may occur. The customer must avoid these errors and that the specifications of the operating and assembly line are observed. The information listed is only used as a guide to troubleshooting. When searching for the cause of failure, the adjacent components must also be included in the fault analysis.



Directive 2014/34/EU requires the user and the manufacturer to pay particular attention to the use of the coupling, as the coupling can become an ignition source in the event of improper use.

Common errors:

- The necessary data for the design of the coupling were not provided or passed on incorrectly.
- No calculation of the shaft-hub connection has been performed.
- Products with transport damage were nevertheless assembled.
- The permissible temperature was not observed when mounting the hubs by warming them up.
- The fits of the hubs are not concentric to each other.
- Tightening torques have not been selected correctly.
- The assembly of the spider was neglected or incorrectly carried out.
- Maintenance intervals were not observed as prescribed.
- Third-party products were installed.

Faults/Errors	Causes	Important information for explosion hazard areas	Solutions
Increase of operating noise and/or vibrations	The hubs are not exactly aligned with each other	-temperatures on the spider surface too high -risk of ignition from surfaces that are too hot	1. Isolate the system 2. Restore the exact alignment of the hubs, for example, using a feeler gauge 3. Carry out a wear test
	Contact of the jaws due to excessive wear on the spider	-Risk of ignition due to metal contact (spark formation)	1. Isolate the system 2. Dismantle the coupling 3. Carry out a visual inspection of the coupling 4. Replace the spider with a new one 5. Reinstall the coupling 6. Check alignment
	The set screw for the axial hub lock has come loose	-Sparking -risk of ignition from surfaces that are too hot	1. Isolate the system 2. Check the alignment of the coupling 3. Tighten the set screw to the specified torque 4. Carry out a wear test

Faults/Errors	Causes	Important information for explosion hazard areas	Solutions
"Jaw" breaks off on the hub	Excessive vibrations in the driveline	-Sparking -Risk of ignition from surfaces that are too hot	1. Isolate the system 2. Replace the coupling 3. Align new coupling
	Excessive shock loads		1. Isolate the system 2. Eliminate shock loads or re-size coupling 3. Install new coupling 4. Align new coupling
Spider wear before service interval	Excessive vibrations in the driveline	-Sparking -Risk of ignition from surfaces that are too hot	1. Isolate the system 2. Determine and reduce the reason for the vibrations 3. Install a new coupling or dimension a suitable coupling 4. Align new coupling
	Application temperatures are too high		1. Isolate the system 2. Check that the spider used is suitable for the existing temperature. If necessary, change the spider's Shore hardness 3. If the hubs are undamaged, use them again, otherwise replace them with new ones 4. Align the coupling
Spider deformation	Contact with impermissible aggressive oils or media, Ozone exposure, Physical change of the spider due to impermissible ambient temperatures	-Risk of ignition due to metal contact (spark formation)	1. Isolate the system 2. Check and ensure the spider is stable or prevent ozone exposure and ambient temperatures that are not permitted 3. If the hubs are undamaged, use them again, otherwise replace them with new ones 4. Align the coupling

10.0 Important information for explosion hazard areas

If the SPIDEX® flexible shaft coupling is operated in or in connection with an explosive environment, the following additional information must also be observed.

The SPIDEX® coupling is a device within the meaning of Directive 2014/34/EU and may only be used in or in connection with an explosive environment if the following instructions are observed.

10.1 Permissible coupling versions for the EX area

- Hub with keyway and set screw/cross pin
- Hub without keyway and set screw/cross pin
- Hub with spline and set screw
- Clamping hub with keyway; single slot
- Clamping hub without keyway; single slot
- Clamping hub with spline; single slot
- Clamping hub with keyway; double slot
- Clamping hub without keyway; double slot
- SPIDEX flange

10.2 Permissible coupling materials in explosion hazard areas

The following hub materials may be used in explosion hazard areas:

- Sinter
- Gray cast iron
- Spheroidal cast iron
- Steel
- Die cast aluminum (but not in device group 1)



WARNING!

The individual materials are only partially suitable for the individual classification groups. Please refer to Chapter 10.3.1

10.3 Explosion hazard area operating conditions

The SPIDEX coupling® is designed according to DIN EN ISO 80079-36 or DIN EN ISO 80079-38 without ignition sources according to the respective category. The use of the SPIDEX coupling in connection with an explosive environment depends on the size of the spider. The following approvals apply:

10.3.1 Device groups

In device group I, category M2 or EPL Mb in all sizes up to A125/145 with the designation:

CE  I M2 Ex h Mb

T_a according to operating and assembly instructions

In device group II, category 2G or EPL Gb and gas group IIC up to size A90/100 with the marking:

CE  II 2G Ex h IIC TX Gb

T_a and TX according to operating and assembly instructions

In device group II, category 2G or EPL Gb and gas group IIB in all sizes up to A125/145 with the marking:

CE  II 2G Ex h IIB TX Gb

T_a and TX according to operating and assembly instructions

In device group II, category 2D or EPL Db and dust group IIIC in all sizes up to A125/145 with the marking:

CE  II 2D Ex h IIIC TX Db

T_a and TX according to operating and assembly instructions

10.3.2 Temperature classes, ambient temperature and surface temperature

The permissible ambient temperature T_a as well as the max. surface temperature (for gases and/or dusts) result according to the color of the spider material as follows:

Table 8: Minimum ambient temperature

Color Spider material	Minimum ambient temperature
blue 80° Shore A	-40 °C ≤ T _a
white 92° Shore A	-40 °C ≤ T _a
green 64° Shore A	-20 °C ≤ T _a
red 95/98° Shore A	-30 °C ≤ T _a
yellow 92° Shore A	-50 °C ≤ T _a
light red 95/98° Shore A	-50 °C ≤ T _a
light green 64° Shore D	-50 °C ≤ T _a
natural 95° Shore A	-30 °C ≤ T _a

Table 9: Max. Ambient temperature, temperature class and max. surface temperature

Color Spider material	Maximum ambient temperature
blue 80° Shore A	$T_a \leq 35 \text{ °C}$
white 92° Shore A	$T_a \leq 65 \text{ °C}$
Green 64° Shore D.	$T_a \leq 85 \text{ °C}$
Red 95/98° Shore A.	$T_a \leq 75 \text{ °C}$.
yellow 92° Shore A	$T_a \leq 95 \text{ °C}$
light red 95/98° Shore A	$T_a \leq 95 \text{ °C}$
light green 64° Shore D	$T_a \leq 95 \text{ °C}$
nature 95° Shore A	$T_a \leq 75 \text{ °C}$

The maximum surface temperature TX is 25 K higher than the actual local ambient temperature.

The design limits provided in the SPIDEX® assembly and operating instructions must be observed. The permissible displacement values must not be exceeded. The coupling must not be operated in the range of natural vibrations. Coupling-dependent parameters for the calculation of the self-oscillation are contained in the operating and assembly instructions.

Pre-drilled hubs must be finished with the tolerances specified by R+L. For shaft-hub connections according to the customer's specifications, the customer is responsible for the durability of the connection.

The coupling materials used must not be chemically influenced by the surrounding atmosphere. The resistance of the spider to various chemical substances is specified in the operating and assembly instructions. The resistance of the ring gear to other chemical substances can be requested from R+L.

The exposed surface of the ring gear can be statically charged. Improper charging can occur when the coupling is running in a dust spill. This must be prevented by the operator.

To prevent mechanical ignition sources, metal contact with the rotating coupling must be prevented. This can be done, for example, with a suitable coupling protection (fixed isolating protective device). Openings or gaps in/with the separating protective device must be at least IP 2X according to IEC 60529. In Group I, the coupling guard must be able to withstand the severe operating conditions.

In Group I, aluminum couplings are not offered.

The operator must ensure that the information on the intended operation is observed.

10.4 Health and Safety Information



If the SPIDEX® coupling is used as a component of a device or a module within the meaning of Directive 2014/34/EU, the manufacturer of the device must establish and confirm the conformity of this device or module with the said guideline before first use.

If the SPIDEX® coupling is used as a component of a device or a module within the meaning of Directive 94/9EG, the device manufacturer must establish and confirm the conformity of this device or module with the said Directive before first use. It is the responsibility of the operator to check whether the SPIDEX® coupling is suitable for operation in the actual explosive atmosphere based on the instructions for use.

Protection Note	Drawn: 02/05/2020 Eata	Replacement for: 10/05/2010 Mboz
Observe ISO 16016	Reviewed: 04/15/2020 Mboz	Replaced by: 02/05/2019 Eata

In trouble-free operation, the SPIDEX® coupling has no effective ignition source. The operator must ensure trouble-free operation by checking, maintaining and repairing the system in accordance with the instructions in the operating instructions.

The operator must stop a coupling that is not working properly. The coupling must not be put back into operation until it has been repaired.

Maintenance or inspection work on the SPIDEX® coupling should not be carried out in an explosive atmosphere.

No burning, welding or separation work is required for maintenance and inspection.

Protective measures in accordance with Directive 1999/92/EC, e.g. according to DIN EN 1127-1 Annex a, must be taken on-site for work in an explosive atmosphere. Smoking, fire and open light must be prohibited.

10.5 Installation and assembly



The coupling halves must be secured against axial movement. If the coupling halves are not tightened against a shaft shoulder, they must be secured with a locking screw. The locking screw must be secured against loosening with an adhesive, Loctite 243 or equivalent. The adhesive must have a temperature resistance of at least 125 °C (max. surface temperature 105 °C).

In the case of shaft-hub connections with a cross pin, the customer must secure the cross pin against loosening.

In order to prevent metal contact, the coupling halves must be fitted with the specified clearance “s”.

All screws must be tightened to the specified torque.

The spider consists of an insulating material and prevents direct potential equalization between the coupling halves. Potential equalization between the coupling halves must be ensured on the system side.

10.6 Checks, inspection and repair



To prevent and detect faults, the following information must be observed in addition to the inspection notes in the operating and assembly instructions.

Faults must be rectified immediately, observing the repair instructions.

In daily checks, care must be taken for changes in running noise or vibrations.

The spider may wear out due to friction, so that the coupling halves can contact each other and cause a spark of ignition. Therefore, wear and tear must be checked regularly in accordance with the operating and assembly instructions. Replace the spider before improper wear occurs.

Only the manufacturer-specified and approved spare parts may be used to maintain the explosion protection concept.

10.7 Checking



In accordance with Directive 1999/92/EC, the SPIDEX coupling must be checked for correct assembly and correct functioning by a qualified person or by an employee of R+L Hydraulics GmbH, Werdohl, prior to first use. This check must be documented.

According to Directive 1999/92/EC, the SPIDEX coupling must be checked for correct functioning by a qualified person or an employee of R+L Hydraulics GmbH, Werdohl, at the latest after 3 years. This check must be documented.

11.0 Additional Information:



For all subsequent operations on the coupling components, which were not carried out by R+L Hydraulics GmbH, the customer bears the sole responsibility.
Any warranty claims are excluded.



Any rework on coupling components that are intended for use in explosion hazard areas, and which were not carried out by R+L Hydraulics GmbH, voids the EX-suitability immediately.
Furthermore, the customer is solely responsible.
Any warranty claims are excluded.

Below is the EC declaration of conformity for R+L Hydraulics of the SPIDEX jaw coupling. The customer may optionally obtain the Declaration of Conformity with the delivery of the coupling or by e-mail.

Protection Note	Drawn: 02/05/2020 Eata	Replacement for: 10/05/2010 Mboz
Observe ISO 16016	Reviewed: 04/15/2020 Mboz	Replaced by: 02/05/2019 Eata

EU - Declaration of Conformity

as defined in the explosion protection directive 2014/34/EU

The following company: R+L Hydraulics GmbH
Friedrichstrasse 6
58791 Werdohl

is solely responsible for ensuring that the operating & assembly instructions described in the

device: SPIDEX clutch

complies with the basic health and safety requirements of Directive 2014/34/EU, Annex II. The possible uses are derived from the labeling and the instructions for use in the “Ex” supplement to the assembly and operating instructions.

The following harmonized standards and/or normative documents have been considered, in whole or in part, with the design and manufacturing of this device:

European Standards	National standards / normative documents
DIN EN 1127-1:2011 DIN EN 15198:2007 DIN EN ISO 80079-36:2016 DIN EN ISO 80079-38:2017 DIN EN ISO 80079-37:2017	

The special notes in the “Ex supplement” for operating and assembly instructions must be observed.

The technical documentation referred to in Annex VIII, No. 3 has been prepared and filed with the notified body **IBExU**. The filing number is **IB034179 E2**.

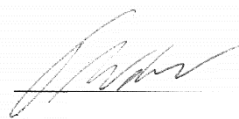

Werdohl, 03.03.2023
Place / Date

Timo Weber / General Manager
Name / Function / Signature

Protection Note	Drawn: 02/03/2023 AMin	Replacement for: 10/05/2010 Mboz
Observe ISO 16016	Reviewed: 03/03/2023 Mboz	Replaced by: 02/03/2023 AMin