

Damping rails

Operating / Installation manual

BMA0004

Table of contents:

| | |
|--|----------|
| 1.0 General information: | 2 |
| 1.1 Safety and information symbols: | 2 |
| 1.2 General hazard warnings:..... | 2 |
| 2.0 Intended use: | 3 |
| 3.0 Dimensions: | 3 |
| Figure 1: Diagram of the damping rods..... | 3 |
| Table 1: Damping rail dimensions | 4 |
| 3.1 Purpose of the different versions..... | 4 |
| 4.0 Assembly | 5 |
| 4.1 Loads | 5 |
| Table 2: Tightening torques | 5 |
| 4.2 Fitting the MDL damping rods to the electric motor..... | 5 |
| Figure 2: Exploded diagram: MDL damping rods / Electric motor | 6 |
| 4.3 Fitting the PTFL / PTFS damping rods to the foot bracket..... | 6 |
| Figure 3: Exploded diagram: PTFL damping rods / Electric motor | 7 |
| Figure 4: Exploded diagram: PTFS damping rods / Electric motor | 7 |
| 5.0 Additional information: | 7 |

| | | |
|---|--|--|
| Raja-Lovejoy GmbH Friedrichstr. 6 D-58791 Werdohl | Damping rods operating / installation manual | Number: BMA0004 Page: 2 of 7 Version: 1ENG |
|---|--|--|

The damping rods are used to damp vibrations and lower the sound level produced by the unit.

1.0 General information:

Carefully read through this installation manual before installing the damping rods.

Pay particular attention to the safety instructions!

The installation manual is part of your product. Store it carefully and in the vicinity of the damping rods.

The copyright for this installation manual shall remain with **Raja-Lovejoy GmbH**.

1.1 Safety and information symbols:



Danger Risk of injury to personnel



Caution Damage could occur to the machine



Note Note regarding important information

1.2 General hazard warnings:



During installation and removal of the damping rods, make sure that the entire drive train is secured to prevent accidental activation, and that the system is depressurised. Improper handling of the damping rods can cause serious injury. For this reason, the following safety instructions should be read and followed without exception.

- All work on the damping rods should be performed from the perspective of

->“Safety First”

- Secure the drive unit to prevent unintentional activation, e.g. by attaching information signs to the switch-on points or removing the fuse at the power supply.
- Secure the unit before tipping it. Attach the relevant protective devices and supports.

| | | |
|--|---|----------------------------------|
| Copyright reserved as per ISO 16016 | Signed: 01.10.2010 MBOZ Checked: 01.04.2011 JZIS | Replacement for: Replaced by: |
|--|---|----------------------------------|

2.0 Intended use:

You may only install and maintain the damping rods if you:

- have carefully read and understood the installation manual
- are authorised and trained to do so

The damping rods may only be used in accordance with the technical specifications. Unauthorised structural changes to the damping rods are prohibited. We will not accept any liability for damage occurring as a result of this. In the interest further development, we reserve the right to make technical changes. The damping rods described here correspond with the latest technical standards at the time of publication of this installation manual. The damping rods are usually delivered ready for installation.

3.0 Dimensions:

Figure 1: Diagram of the damping rods

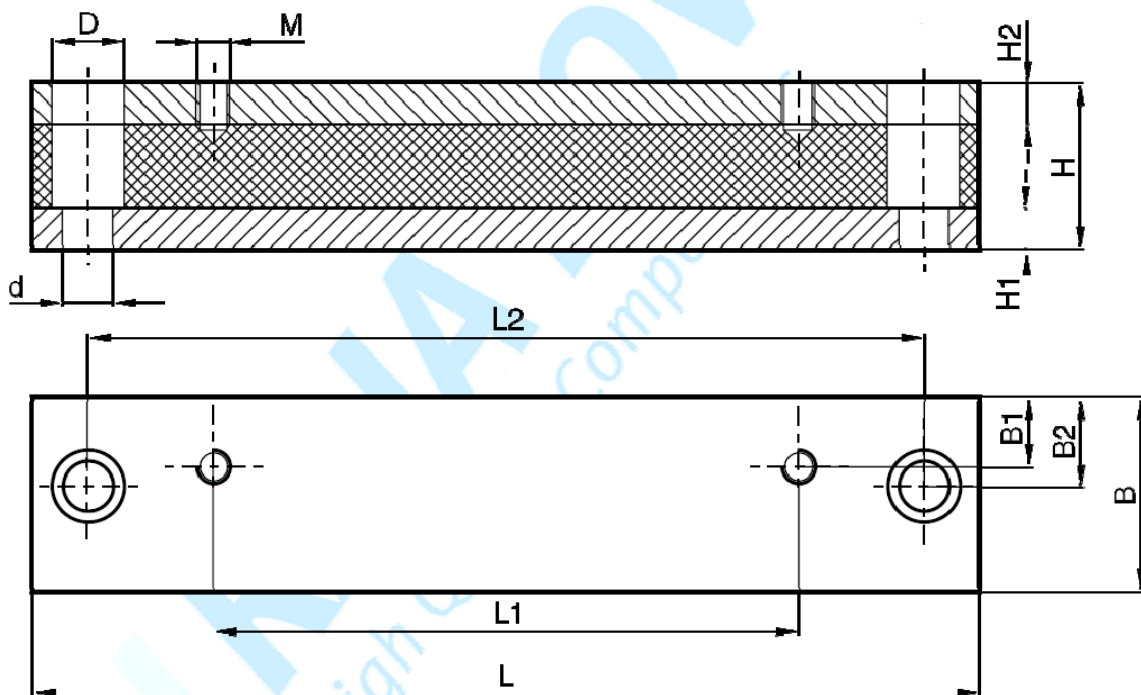

Table 1: Damping rail dimensions

| Damping rails | For type | L | L1 | L2 | H | H1 | H2 | B | B1 | B2 | d | D | M |
|----------------------------|----------|-----|-----|-----|----|----|----|-----|----|----|----|----|-----|
| <i>For electric motors</i> | | | | | | | | | | | | | |
| MDL 71 | 71 | 196 | 90 | 156 | 40 | 8 | 12 | 50 | 21 | 25 | 14 | 20 | M6 |
| MDL 80 | 80 | | 100 | 156 | | | | | 22 | | | | M8 |
| MDL 90S | 90S | 196 | | | | | | | | | | | |
| MDL 90L | 90L | 240 | 125 | 205 | | | | | 24 | | | | |
| MDL 100L | 100L | | 140 | | | | | | | | | | M10 |
| MDL 112M | 112M | | | | | | | | 20 | | | | |
| MDL 132S | 132S | 285 | | 245 | 45 | | | | | | | | |
| MDL 132M | 132M | | 178 | | | | | | | | | | |
| MDL 160M | 160M | 340 | 210 | 300 | 60 | 15 | 15 | 70 | 28 | 35 | 18 | 26 | M12 |
| MDL 160L | 160L | 416 | 254 | 370 | | | | | | | | | |
| MDL 180M | 180M | | 241 | | | | | | 35 | | | | |
| MDL 180L | 180L | 446 | 279 | 400 | | | | | | | | | |
| MDL 200L | 200L | 496 | 305 | 430 | | | | | | | 22 | 32 | M16 |
| MDL 225S | 225S | | 286 | | | | | | | | | | |
| MDL 225M | 225M | | 311 | 445 | | | | | | | | | |
| MDL 250M | 250M | | 349 | | | | | 100 | 50 | 50 | 25 | 40 | M20 |
| MDL 280S | 280S | 580 | 368 | 530 | | | | | | | | | |
| MDL 280M | 280M | | 419 | | | | | | | | | | |
| MDL 315S | 315S | 660 | 406 | 610 | 70 | | | 150 | 60 | 75 | 25 | 40 | M24 |
| MDL 315M | 315M | | 457 | | | | | | | | | | |
| MDL 315L | 315L | 720 | 508 | 670 | | | | | | | | | |
| <i>For footbrackets</i> | | | | | | | | | | | | | |
| PTFSDL 250 | PTFS 250 | 290 | 185 | 260 | 40 | 8 | 12 | 50 | 20 | 25 | 14 | 20 | M12 |
| PTFSDL 300 | PTFS 300 | 350 | 225 | 300 | | | | | | | | | |
| PTFSDL 350 | PTFS 350 | 375 | 265 | 340 | 60 | | | 70 | 30 | 35 | 18 | 26 | M16 |
| PTFSDL 400 | PTFS 400 | 420 | 300 | 385 | | 15 | 15 | | | | | | |
| PTFSDL 450 | PTFS 450 | 455 | 335 | 420 | | | | | | | | | |
| PTFSDL 550 | PTFS 550 | 535 | 415 | 500 | | | | | | | | | |
| PTFSDL 660 | PTFS 660 | 660 | 495 | 610 | | | | | | | 22 | 32 | M20 |
| PTFLDL 160 | PTFL 160 | 176 | 50 | 130 | 40 | 8 | 12 | 50 | 10 | 25 | 14 | 20 | M8 |
| PTFLDL 200 | PTFL 200 | 176 | 60 | 130 | | | | | 15 | | | | M10 |
| PTFLDL 250 | PTFL 250 | 230 | 60 | 140 | | | | | 15 | | | | M12 |
| PTFLDL 300 | PTFL 300 | 270 | 80 | 170 | | | | | 15 | | | | |

3.1 Purpose of the different versions

MDL = motor damping rods, for installation with IEC electric motors, type IMB 35

PTFLDL = bell housing damping rods – light model, for installation with Raja-Lovejoy PTFL foot bracket

PTFSDL = bell housing damping rods – heavy model, for installation with Raja-Lovejoy PTFS foot bracket

4.0 Assembly



The screws should normally be secured with Loctite, Omnifit 230M or a comparable thread adhesive.



Please note that serious injury may be caused by tipping the unit (crushing). Secure the unit using suitable supports.

4.1 Loads



The standard damping rods are designed to withstand the loads generated during their intended use. Any deviation from this must be approved by Raja-Lovejoy before installation.



The motor feet or bell housing feet must be resting fully on the damping rods.



Shear loads are prohibited and must be avoided at all costs.



All damping rods should only be loaded to their rated pressure. Slight tensile loads, which occur due to the bending moment experienced with horizontal installation, which is caused by uneven weight distribution, are permissible to a low extent.

Table 2: Tightening torques

| Cheese head screw with hexagonal socket acc. to DIN 912 - 8.8 | M8 | M10 | M12 | M16 | M20 |
|---|----|-----|-----|-----|-----|
| Tightening torques T_A [Nm] | 25 | 49 | 86 | 210 | 410 |

4.2 Fitting the MDL damping rods to the electric motor

- Screw the damping rods to the floor / base plate by inserting the screws from above into the countersunk holes, and tightening them to a suitable tightening torque.
- The screw tightening torque is dependent on the material from which the floor / base plate is made. This information can be found in the manufacturer's technical documentation.
- Place the feet of the electric motor on the damping rods.
- Insert the screws with washers through the through-holes of the electric motor feet and screw them into the threaded holes in the damping rods. Preferably, a screw length should be selected which enables the entire thread depth of the threaded holes to be used in the damping rods.
- Please see Table 2 for the screw tightening torques for this.

Figure 2: Exploded diagram: MDL damping rods / Electric motor

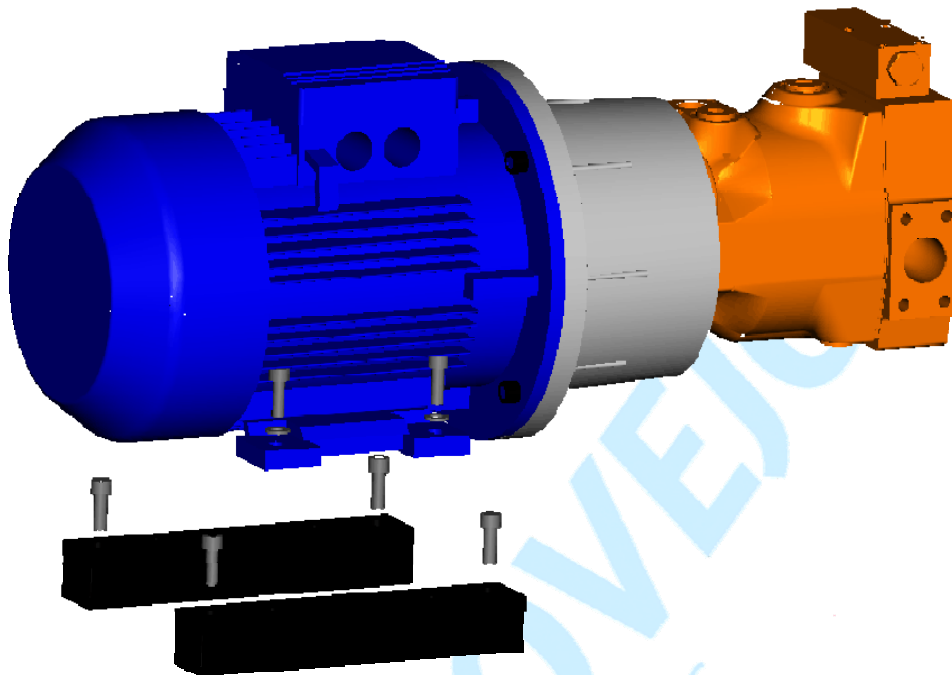

4.3 Fitting the PTFL / PTFS damping rods to the foot bracket

- Screw the damping rods to the floor / base plate by inserting the screws from above into the countersunk holes, and tightening them to a suitable tightening torque.
- The screw tightening torque is dependent on the material from which the floor / base plate is made. This information can be found in the manufacturer's technical documentation.
- Place the bell housing base on the damping rods.
- Insert the screws with washers through the through-holes of the bell housing base and screw them into the threaded holes in the damping rods. Preferably, a screw length should be selected which enables the entire thread depth of the threaded holes to be used in the damping rods.
- Please see Table 2 for the screw tightening torques for this.

Figure 3: Exploded diagram: PTFE damping rods / Electric motor

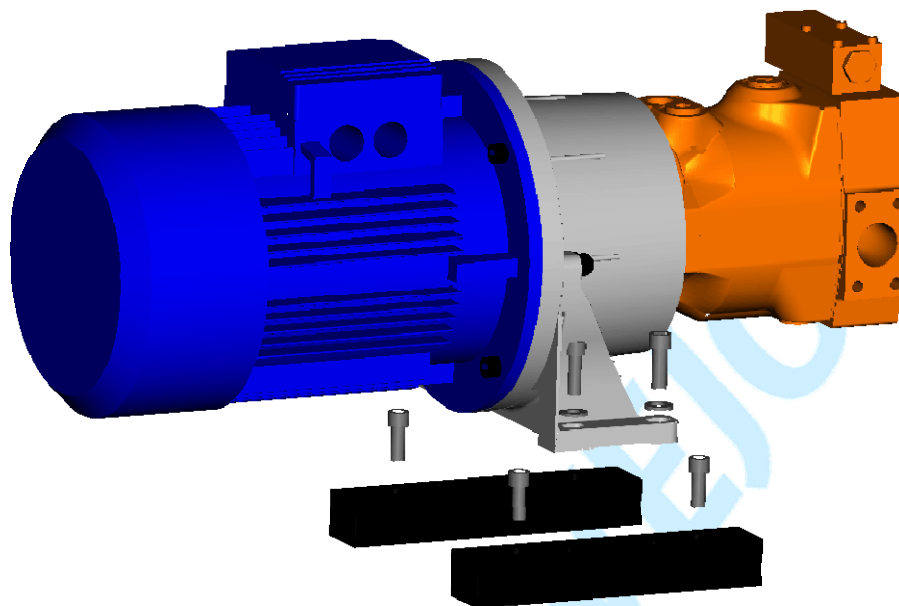
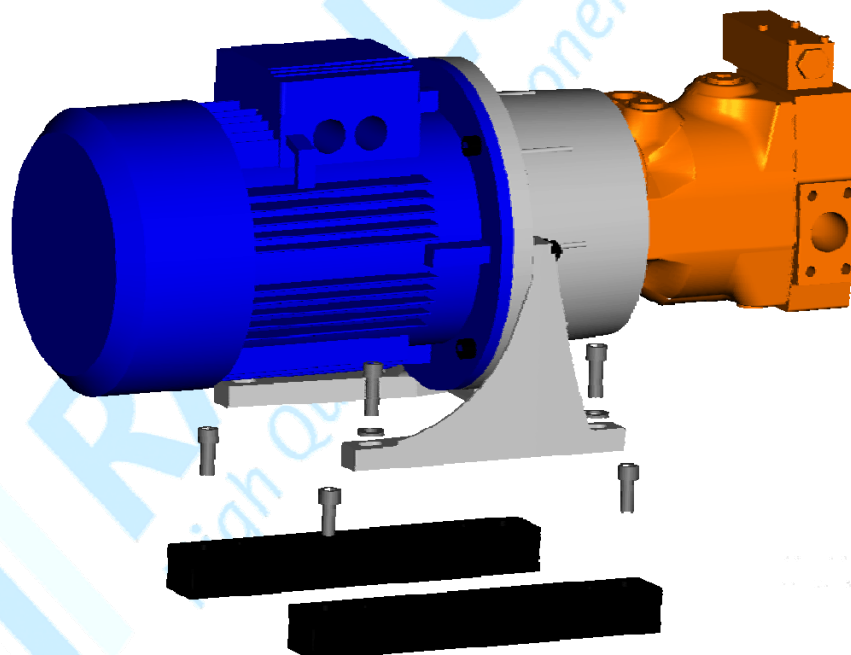

Figure 4: Exploded diagram: PTFE damping rods / Electric motor



5.0 Additional information:

- The damping rods can only be used for horizontal installation!

| | | |
|--|---|----------------------------------|
| Copyright reserved as per ISO 16016 | Signed: 01.10.2010 MBOZ Checked: 01.04.2011 JZIS | Replacement for: Replaced by: |
|--|---|----------------------------------|